

# FLOODSAVER®

## Slide-N-Fold™

A versatile water protection system for dishwashers, air conditioning units and other household appliances.

Slide-N-Fold is designed to protect homes, apartments and condominiums by minimizing the risk of flooding by appliances that are located under counters or in difficult-to-reach locations. Delivered flat, the unit is folded to form a water-tight pan using eight simple screw-rivets.

Prior to installation the sides and back of the unit are assembled, leaving the front side "open." After the unit is positioned and a drain is installed, the appliance is slid onto the unit. Then the front of the unit is folded and "riveted" into place, forming an effective protection against appliance leaks and floods. The screw-rivets can be removed later as needed for appliance maintenance.

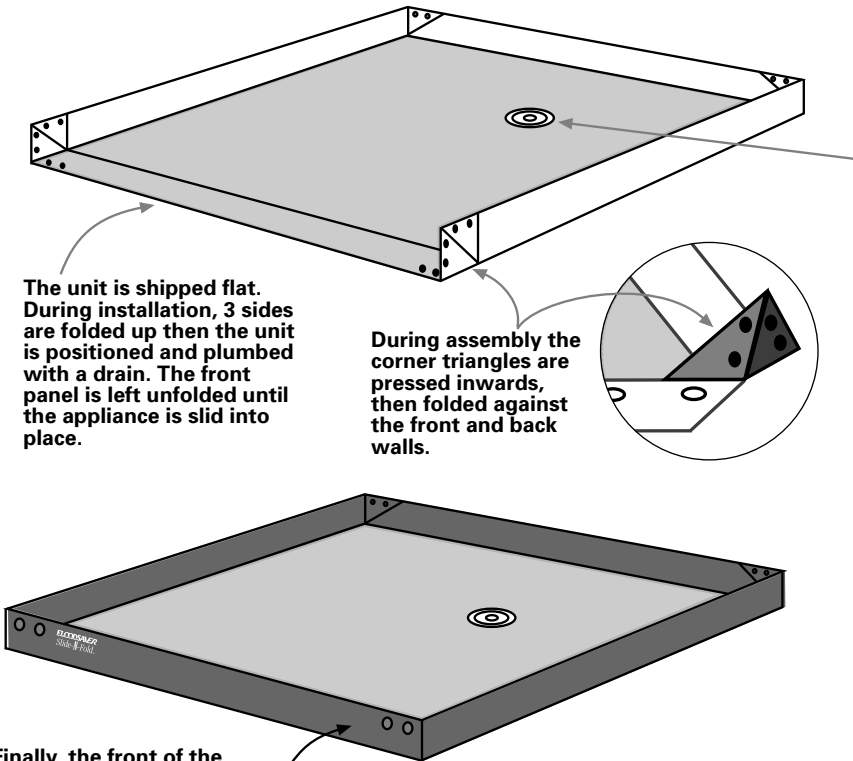

The unit is shipped flat. During installation, 3 sides are folded up then the unit is positioned and plumbed with a drain. The front panel is left unfolded until the appliance is slid into place.

During assembly the corner triangles are pressed inwards, then folded against the front and back walls.

Finally, the front of the unit is folded up into position and the screw rivets are installed.

**WARNING: SHOCK HAZARD.**  
In most applications the Slide-N-Fold unit should be equipped with a drain – especially if there is a potential for water to accumulate in the pan and come in contact with electrical components. Check with your electrician.

### All-Purpose Folding Pan

#### Model #APFP2424

NOTE: All Dimensions are APPROXIMATE

**OUTSIDE DIMENSIONS:**  
Height: 2-3/4" (depth of pan)  
Width: 24-1/8" (side to side)  
Depth: 24-5/8" (front to back)

**INSIDE BASE DIMENSIONS:**  
Width: 24" (side to side)  
Depth: 23-1/4" (front to back)

NOTE: Drains and pipe/trap are not included.

#### Model #APFP2426

**OUTSIDE DIMENSIONS:**  
Height: 2-3/4" (depth of pan)  
Width: 24-1/8" (side to side)  
Depth: 26-7/8" (front to back)

**INSIDE BASE DIMENSIONS:**  
Width: 24" (side to side)  
Depth: 25-3/4" (front to back)

NOTE: Drains and pipe/trap are not included.

**COLOR: Black** US Pat. 5,883,300

#### INSTALLING A DRAIN

Install a shower-type or sink-type drain anywhere that conveniently allows the placement of a trap and under-floor drain line.

#### SUGGESTED SPECIFICATION:

Water containment system shall be FloodSaver® Slide-N-Fold Pan or equivalent. 1-piece system to consist of formed high-density polypropylene. Unit shall form a minimum 2.5" deep containment pan and shall accommodate a standard shower-type or sink-type drain.

Product of:



P.O. Box 1782  
Stanwood, WA 98292  
**(360) 629-9269**  
FAX: (360) 629-2838  
ORDERS: (866) 341-7674

[www.floodsaver.com](http://www.floodsaver.com)